

# INSTALLING PEERLESS WATER SAVER AND ULTRA WATER SAVER TOILETS

1. Trip Lever
2. Water Supply Connection
3. Plastic Washer
4. Supply Coupling Nut
5. Water Supply Line (Not Included)
- 6a. Rubber flat Washer
- 6b. Metal Flat Washer
7. Hex Nut
8. Plastic Bolt Cover
9. Acorn Nut (Not Included)
10. Chrome Washer (Not Included)
11. Wax Bowl Ring (Not Included)
12. Bowl Hold-Down Bolts (Not Included)
13. Tank Lid
14. Tank
- 15a. Rubber Flat Washer
- 15b. Metal Flat Washer
16. Hex Nut
17. Rubber Washer
18. Tank-To Bowl Bolts
19. Rubber Tank-To Bowl Gasket
- 19a. Channel cushions
20. Bowl
21. Floor Flange (Not Included)

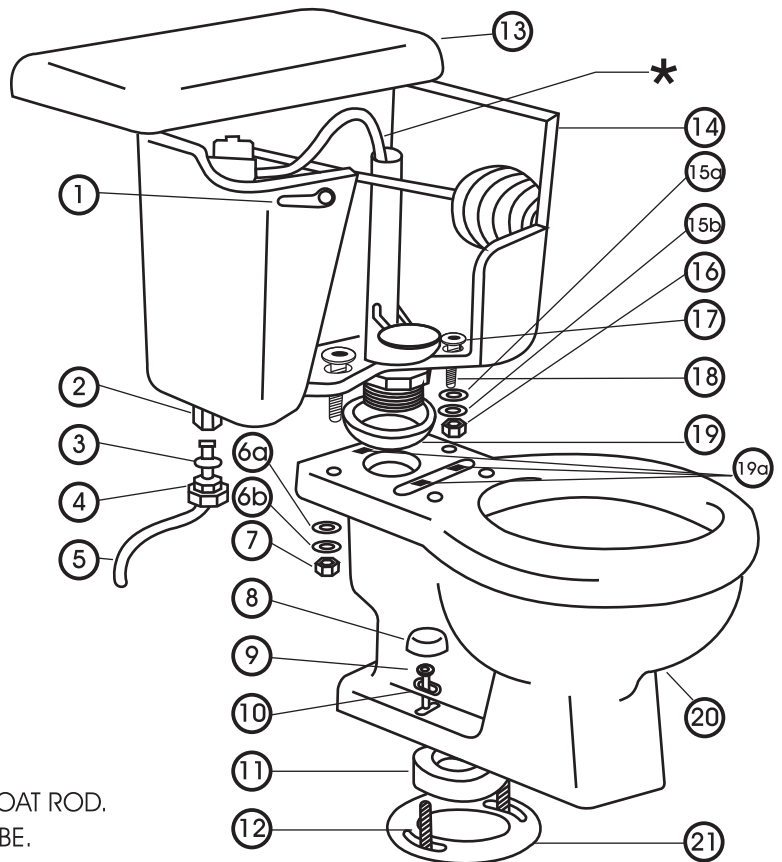

**\* IMPORTANT.** BE SURE REFILL TUBE CROSSES OVER FLOAT ROD.  
BE SURE REFILL TUBE WILL PUT INSIDE THE OVERFLOW TUBE.



## PEERLESS POTTERY SALES, INC.

319 S. 5th St. Suite 12  
Rockport, IN 47635

ANY MODIFICATION TO FLOAT ROD WILL VOID WARRANTY  
SEE REVERSE SIDE FOR DETAILED TANK-TO-BOWL ASSEMBLY

## CARE AND MAINTENANCE INSTRUCTIONS

Under normal circumstances these products should be cleaned with a mild detergent or soap and water. For exceptionally stubborn stains, use a commercially acceptable liquid cleaner. A soft nylon bristle brush in conjunction with a liquid cleaner will assist in cleaning. Do not use abrasive or acidic cleaning materials.

## REPAIR PARTS INFORMATION

Replacement parts for fill and flush valves must be obtained from an authorized dealer.

Contact our customer service department for information on repair parts:

Peerless Pottery Sales Inc. 319 S. 5th St. Suite 12 Rockport, IN 47635

or call: 1 866 4575785.

When contacting our customer service, please have the model number of your toilet and type of ballcock or flush valve installed in the toilet tank.

This information can be obtained by opening your tank lid and finding the manufacturer's name on the ballcock cap and on the flush valve flapper or body.

In case where parts are substituted, Peerless Pottery Sales Inc. will not be responsible for damage caused by parts not supplied by an authorized dealer.

# ASSEMBLY OF PEERLESS WATER SAVER AND ULTRA WATER SAVER TOILETS

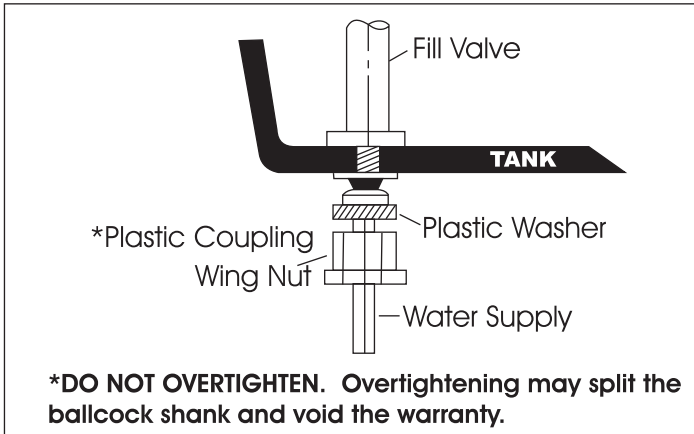

- Parts List**
- 2. Tank-To-Bowl Bolts
  - 2. Hex Nuts
  - 2. Rubber flat washer
  - 2. Metal Flat Washers
  - 2. Rubber Washers (Black)
  - 1. Tank-To-Bowl Gasket (Black)
  - 1. Trip Lever w/Nut (Reverse Thread)
  - 1. Plastic Washer
  - 3. Channel cushions

**NOTE: Do not use pipe dope on any plastic or rubber parts**

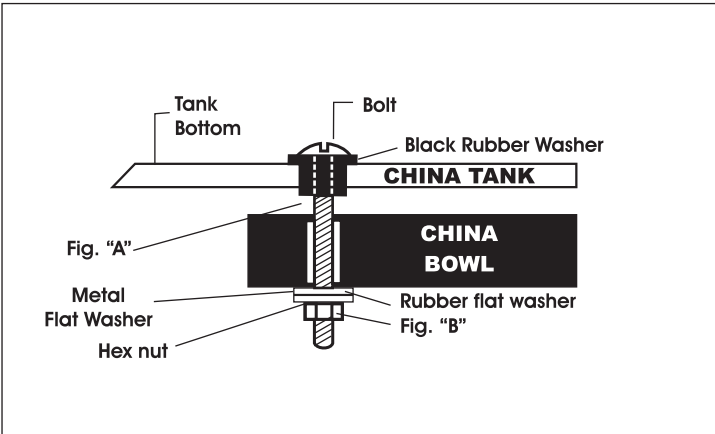

**Fig. "A" Set properly black rubber washer**

**Fig. B Push Down On The Top Of The Tank, One Side At A Time To Tighten Bottom Nuts Under Bowl To Level. Do Not overtighten or piece may crack.**



**PEERLESS POTTERY SALES, INC.**  
319 S. 5th St. Suite 12  
Rockport, IN 47635

**The recommended water supply static pressure range by code is 20 to 80 psi.**

## Adhesive Pads (Bumpers)

# Installation:

**TANK COVER**  
The self-adhesive pads, installed as shown, will cushion the contact and prevent rocking.

- RECOMMENDED SEAT**
- To round front toilet
- \*INTERCOMERCE- Venecia (closed front, with cover)
  - \*BEMIS 6900 (closed front, with cover)
  - \*BEMIS 655C (open front, less cover)
- To elongated front toilet:
- \*INTERCOMERCE-Countour (closed front, with cover)
  - \*BEMIS 170AR (closed front, with cover)
  - \*BEMIS 1955C (open front, less cover)